

产品尺寸图 (DIMENSION)

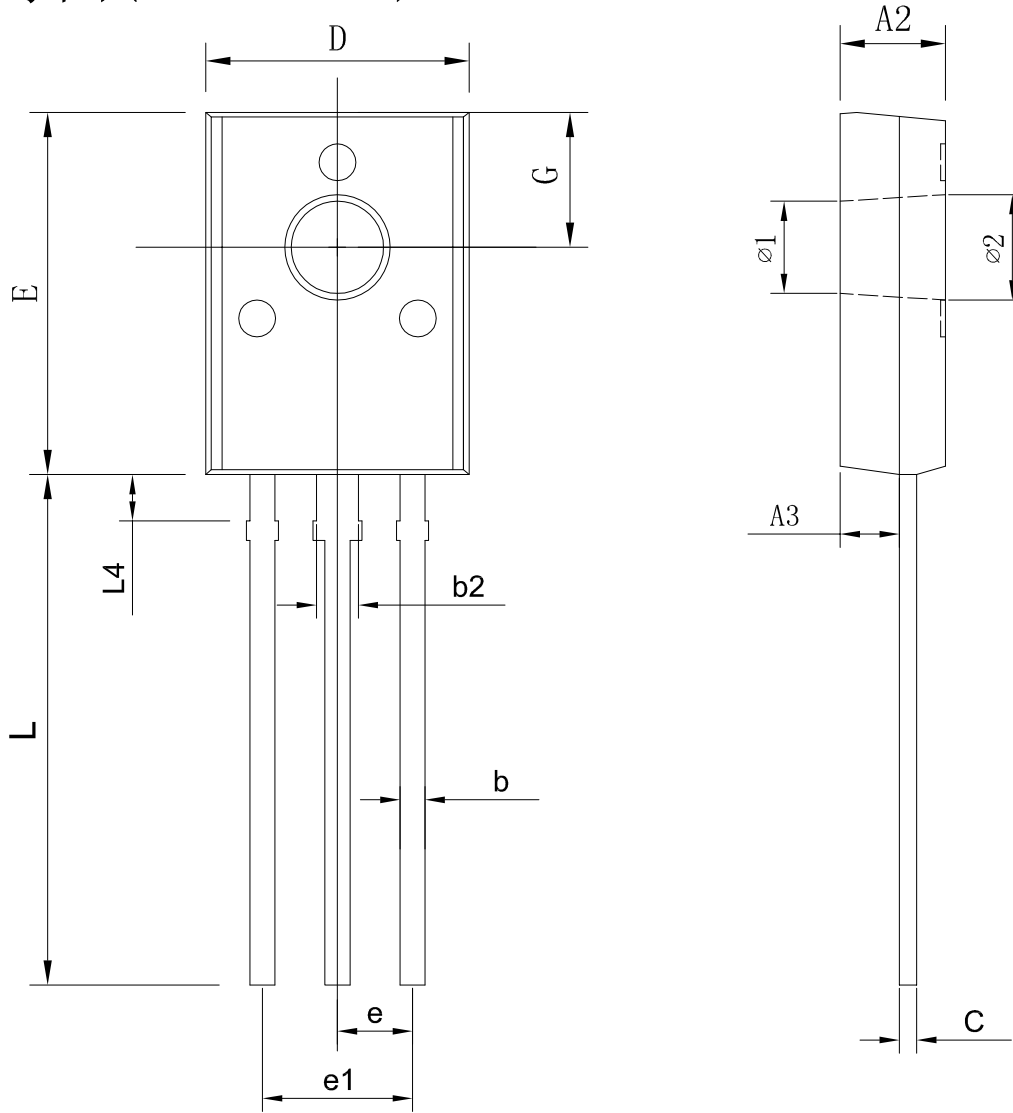

symbol	Dimensions In Millimeters			Dimensions In Inches		
	Min	Nom	Max	Min	Nom	Max
A2	3.000	3.200	3.400	0.118	0.126	0.134
A3	1.800	2.000	2.200	0.071	0.079	0.087
b	0.660	0.760	0.860	0.026	0.030	0.034
b2	1.170	1.270	1.370	0.046	0.050	0.054
c	0.450	0.520	0.600	0.018	0.020	0.024
D	7.800	8.000	8.200	0.307	0.315	0.323
E	10.80	11.00	11.20	0.425	0.433	0.441
e	2.280TYP.			0.090TYP.		
e1	4.460	4.560	4.660	0.176	0.180	0.183
G	4.040	4.140	4.240	0.159	0.163	0.167
L	15.30	15.50	15.70	0.602	0.610	0.618
L4	1.300	1.400	1.500	0.051	0.055	0.059
ø1	3.030	—	3.050	0.119	—	0.120
ø2	3.195	—	3.200	0.125	—	0.126

FSMC

图名 NAME	TO-126C	图号 DWG. NO.	DD0039-F	SH 1 OF 1
材质 MATERIAL	Cu	REV.	F	
单位 UNITS	mm [INCH]	核准 APPROVE	审核 CHECKED	制图 DRAWN
日期 DATE	2011.01.26			
比例 SCALE	N. T. S.			

